

ANG

F A S T

BAĞLANTI ELEMANLARI PERÇİN KATALOĐU

FASTENERS RIVET CATALOGUE



Merhaba,

Sizlere, perçin üretiminin yeni yükselen markası ANG FAST'in perçin konusundaki uzmanlığını ve kalite odaklı hizmetini sunmaktan gurur duyuyoruz.

Perçin, çoğu sektörde üretimin temelini oluşturuyor. Bu bilinç ile her zaman yüksek kalite ve en doğru bağlantı elemanını sizlere tedarik etmeye çalışıyoruz. Her ürünümüz, en yüksek kalite standartlarına uygun olarak üretilir ve titizlikle kontrol edilir. Siz değerli müşterilerimizin ihtiyaçlarına en uygun çözümleri sunmak için sürekli olarak kendimizi geliştiriyor ve yeniliklere açık oluyoruz.

ANG FAST olarak, sadece ürünlerimizle değil, aynı zamanda sunduğumuz hizmetle de fark yaratmayı hedefliyoruz. Size en iyi tedarik servisini sunarak, projelerinizi en başarılı şekilde tamamlamanız için yanınızdayız.

Hello,

We take pride in presenting to you the expertise in rivet production and quality-focused service of ANG FAST, the emerging brand in the field of rivets.

Rivets form the cornerstone of production in most industries. With this awareness, we always strive to supply you with high quality and the most accurate fastening elements. Each of our products is manufactured in accordance with the highest quality standards and meticulously inspected.

We continuously develop ourselves and remain open to innovations in order to provide you with the most suitable solutions for your valuable needs.

At ANG FAST, our aim is not only to stand out with our products but also with the services we provide. We are here to support you in completing your projects with the utmost success by offering you the finest supply service.

ANG
F A S T

Yuvarlak Başlı Perçin



DIN 660

Havşa Başlı Perçin



DIN 661

Mercimek Havşa Başlı Perçin



DIN 662

Mercimek Başlı Perçin



DIN 674

İnce Havşa Başlı Perçin



DIN 675

Düz Başlı Perçin



DIN 7338-A

Yuvarlak Baş Yarım Delik Perçin



DIN 6791

Düz Başlı Yarım Delik Perçin



DIN 7338-B

Kademeli Delikli Perçin



Alüminyum Perçin



Pop Perçin



Özel Perçin



DIN 660

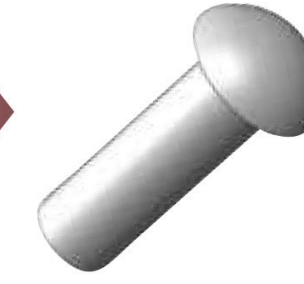

ROUND HEAD RIVETS
YUVARLAK BAŞLI PERÇİN

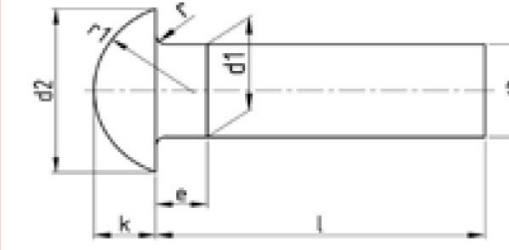

d1	1	1,2	1,4	1,6	2	2,5	3	3,5	4	5	6	7	8	
d1 max.	1,05	1,25	1,45	1,65	2,1	2,6	3,1	3,6	4,1	5,15	6,15	7,15	8,15	
d1 min.	0,95	1,15	1,35	1,55	1,9	2,4	2,9	3,4	3,9	4,85	5,85	6,85	7,85	
d2 max.	1,8	2,1	2,4	2,8	3,5	4,4	5,2	6,2	7	8,8	10,5	12,4	14	
d2 min.	1,55	1,85	2,15	2,55	3,2	4,1	4,9	5,62	6,42	8,22	9,8	11,7	13,4	
d3 min.	0,93	1,13	1,33	1,52	1,87	2,37	2,87	3,37	3,87	4,82	5,82	6,82	7,76	
e max.	0,5	0,6	0,7	0,8	1	1,25	1,5	1,75	2	2,5	3	3,5	4	
k max.	0,725	0,825	0,925	1,125	1,375	1,625	1,925	2,225	2,525	3,15	3,75	4,35	4,95	
k min.	0,475	0,575	0,675	0,875	1,075	1,375	1,675	1,975	2,275	2,85	3,45	4,05	4,65	
r max.	0,2								0,3		0,4			
r1≈	1	1,2	1,4	1,6	1,9	2,4	2,8	3,4	3,8	4,6	5,7	6,6	7,5	

COUNTERSUNK HEAD RIVETS
HAVŞA BAŞLI PERÇİN

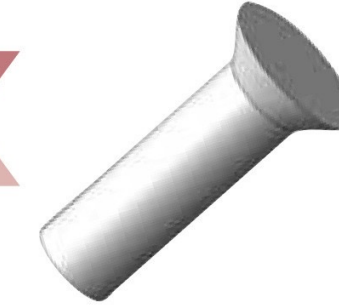

DIN 661

d1	1	1,2	1,4	1,6	2	2,5	3	3,5	4	5	6	7	8
d1 max.	1,05	1,25	1,45	1,65	2,1	2,6	3,1	3,6	4,1	5,15	6,15	7,15	8,15
d1 min.	0,95	1,15	1,35	1,55	1,9	2,4	2,9	3,4	3,9	4,85	5,85	6,85	7,85
d2 max.	1,8	2,1	2,5	2,8	3,5	4,4	5,2	6,3	7	8,8	10,5	12,2	14
d2 min.	1,55	1,85	2,25	2,55	3,2	4,1	4,9	5,72	6,42	8,22	9,8	11,5	13,4
d3 min.	0,93	1,13	1,33	1,52	1,87	2,37	2,87	3,37	3,87	4,82	5,82	6,82	7,76
e max.	0,5	0,6	0,7	0,8	1	1,25	1,5	1,75	2	2,5	3	3,5	4
k ≈	0,5	0,6	0,7	0,8	1	1,2	1,4	1,8	2	2,5	3	3,5	4

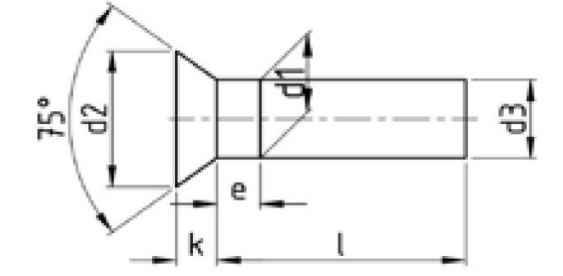

DIN 662

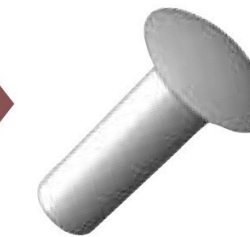

RAISED COUNTERSUNK HEAD RIVETS
MERCİMEK HAVŞA BAŞLI PERÇİN

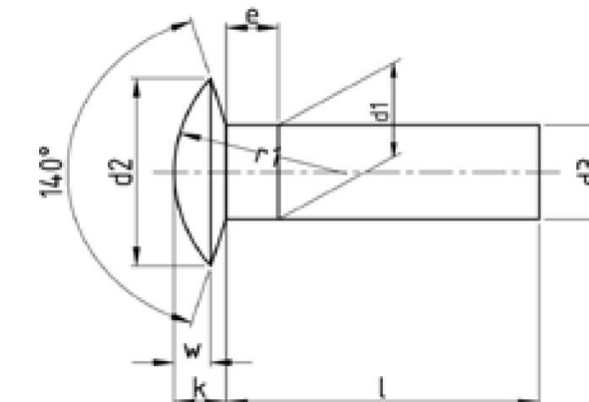

d1	1,6	2	2,5	3	3,5	4	5	6
d1 max.	1,65	2,1	2,6	3,1	3,6	4,1	5,15	6,15
d1 min.	1,55	1,9	2,4	2,9	3,4	3,9	4,85	5,85
d2 max.	3,2	4	5	6	7	8	10	12
d2 min.	2,9	3,7	4,7	5,64	6,42	7,42	9,3	11,4
d3 min.	1,52	1,87	2,37	2,87	3,37	3,87	4,82	5,82
e max.	0,8	1	1,25	1,5	1,75	2	2,5	3
k ≈	0,9	1	1,2	1,5	1,8	2,1	2,5	3
r1 ≈	2,8	3,3	4,2	5	6	6,5	8,2	10
w ≈	0,6	0,7	0,8	1	1,2	1,4	1,7	2

RAISED HEAD RIVETS

MERCİMEK BAŞLI PERÇİN



DIN 674

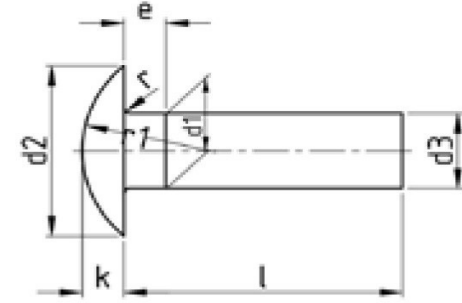

d1	1,4	1,6	2	2,5	3	3,5	4	5	6
d1 max.	1,45	1,65	2,1	2,6	3,1	3,6	4,1	5,15	6,15
d1 min.	1,35	1,55	1,9	2,4	2,9	3,4	3,9	4,85	5,85
d2 max.	3,2	3,6	4,5	5,6	6,8	7,8	9	11,2	13,5
d2 min.	2,9	3,3	4,2	5,3	6,44	7,22	8,42	9,3	11,3
d3 min.	1,33	1,52	1,87	2,37	2,87	3,37	3,87	4,82	5,82
e max.	0,7	0,8	1	1,25	1,5	1,75	2	2,5	3
k ≈	0,7	0,8	1	1,3	1,5	1,8	2	2,5	3
r max.	0,2			0,3			0,4		
r1≈	2,8	3	3,6	4,2	5,4	6,1	7,1	8,8	10,7

DIN 675

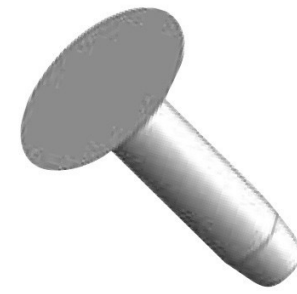

FLAT COUNTERSUNK HEAD RIVETS

İNCE HAŞA BAŞLI PERÇİN

d1	3	4	5
d1 max.	3,1	4,1	5,15
d1 min.	2,9	3,9	4,85
d2 max.	8,3	11	13,8
d2 min.	7,94	10,3	13,1
d3 min.	2,87	3,87	4,83
d5 max.	2,4	3,2	4,2
d5 min.	2	2,8	3,8
e max.	1,5	2	2,5
k ≈	1	1,3	1,6
l1	2	3	3,5

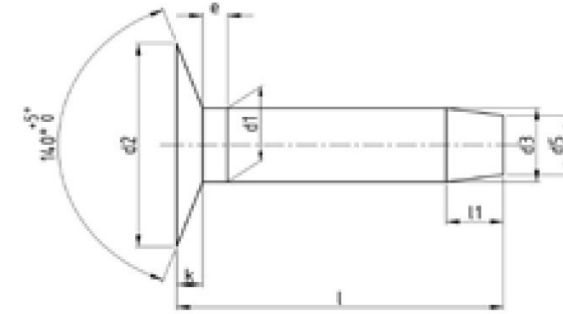

SOLID RIVETS

DÜZ BAŞLI PERÇİNİ



DIN 7338 - A

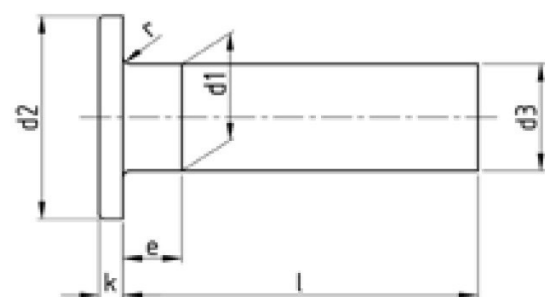

d1	3	4	5	6	8	10
d1 min.	2,86	3,82	4,82	5,82	7,78	9,78
d2 max.	5,5	7,5	9,5	11,5	15,5	18
d2 min.	5,2	6,92	8,93	10,8	14,8	17,16
d3 min.	2,85	3,8	4,8	5,8	7,75	9,75
e max.	1,5	2	2,5	3	4	5
r max.	0,2	0,3		0,4		0,6
k max.	0,8	1	1	1,2	1,2	1,4
k min.	0,6	0,8	0,8	1	1	1,2

DIN 6791

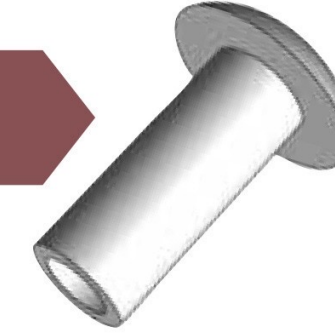

SEMI TUBULAR PAN HEAD RIVETS

YUVARLAK BAŞI YARIM DELİK PERÇİN

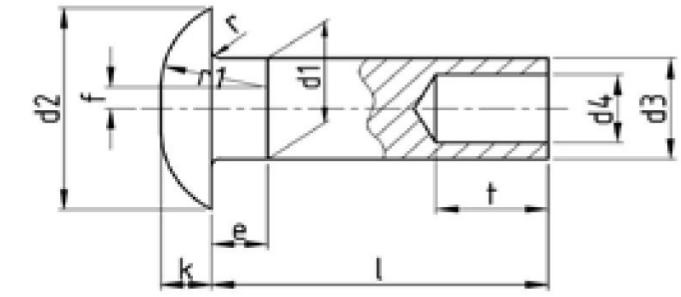

d1	1,6	2	2,5	3	3,5	4	5	6	8	10
d1 max.	1,65	2,1	2,6	3,1	3,6	4,1	5,15	6,15	8,15	10,2
d1 min.	1,55	1,9	2,4	2,9	3,4	3,9	4,85	5,85	7,85	9,8
d2 max.	3,2	4	5	6	7	8	10	12	16	20
d2 min.	2,9	3,7	4,7	5,64	6,42	7,42	9,3	11,3	15,3	10,7
k max.	0,825	1,025	1,225	1,425	1,625	1,925	2,325	2,725	3,65	4,55
k min.	0,575	0,775	0,975	1,175	1,375	1,675	2,075	2,475	3,35	4,25
d3 min.	1,52	1,87	2,37	2,87	3,37	3,87	4,82	5,82	6,82	9,4
d4 max.	1,04	1,34	1,84	2,04	2,34	2,84	3,68	4,38	6,18	7,81
d4 min.	0,9	1,2	1,7	1,9	2,2	2,7	3,5	4,2	6	7,6
e max.	0,8	1	1,25	1,5	1,75	2	2,5	3	4	5
f	0,4	0,5	0,6	0,8	0,9	1	1,3	1,5	2	2,5
r max.	0,2			0,3			0,4			0,5
r1≈	1,4	1,8	2,2	2,6	3	3,5	4,4	5,2	7	8,8
t max.	2	3	3	3,5	4,5	4,5	5,5	7	8,5	10,5
t min.	1,5	2,5	2,5	3	4	4	5	6,5	8	10

SEMI TUBULAR RIVETS

DÜZ BAŞLI YARIM DELİK PERÇİN



DIN 7338 - B

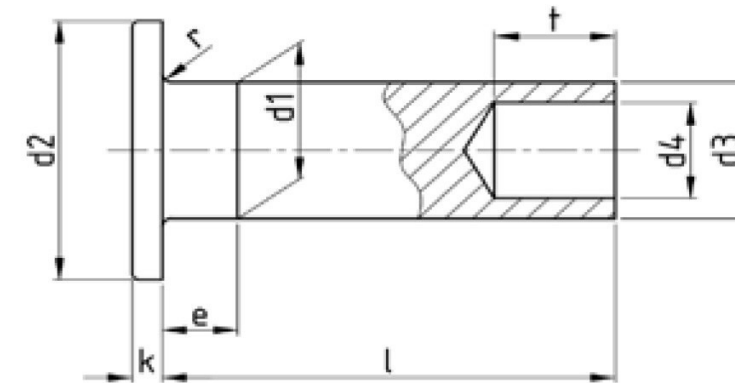

d1	3	4	5	6	8	10
d1 min.	2,86	3,82	4,82	5,82	7,78	9,78
d2 max.	5,5	7,5	9,5	11,5	15,5	18
d2 min.	5,2	6,92	8,93	10,8	14,8	17,16
k max.	0,8	1	1	1,2	1,2	1,4
k min.	0,6	0,8	0,8	1	1	1,2
d3 min.	2,85	3,8	4,8	5,8	7,75	9,75
d4 max.	1,84	2,84	3,68	4,38	6,22	7,72
d4 min.	1,7	2,7	3,5	4,2	6	7,5
e max.	1,5	2	2,5	3	4	5
r max.	0,2	0,3	0,4		0,6	
t max.	4,5	5,5	6,5	8,5	10,5	12,5
t min.	3,5	4	4	6	8	10



ANG
F A S T

ANG FAST MÜHENDİSLİK VE SANAYİ TİCARET LİMİTED ŞİRKETİ

Ramazanoğlu Mahallesi Karşı Geçit Sokak Hisar Sanayi Sitesi No:1 Pendik İSTANBUL



angfast.com



info@angfast.com